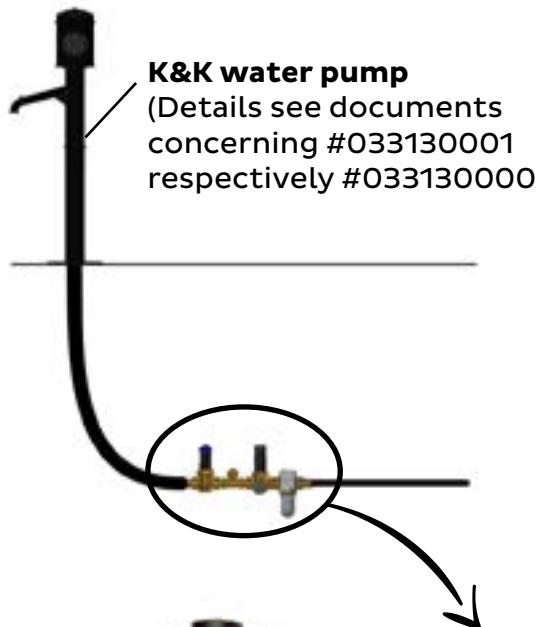

**K&K Valve combination #033190000-A**

for operation of a K&K water pump (#033130000, #033130001, #033131000) on a pressurized water line.

Scope of delivery:

1x valve combination, compl. pre-assembled

Weight 7 kg

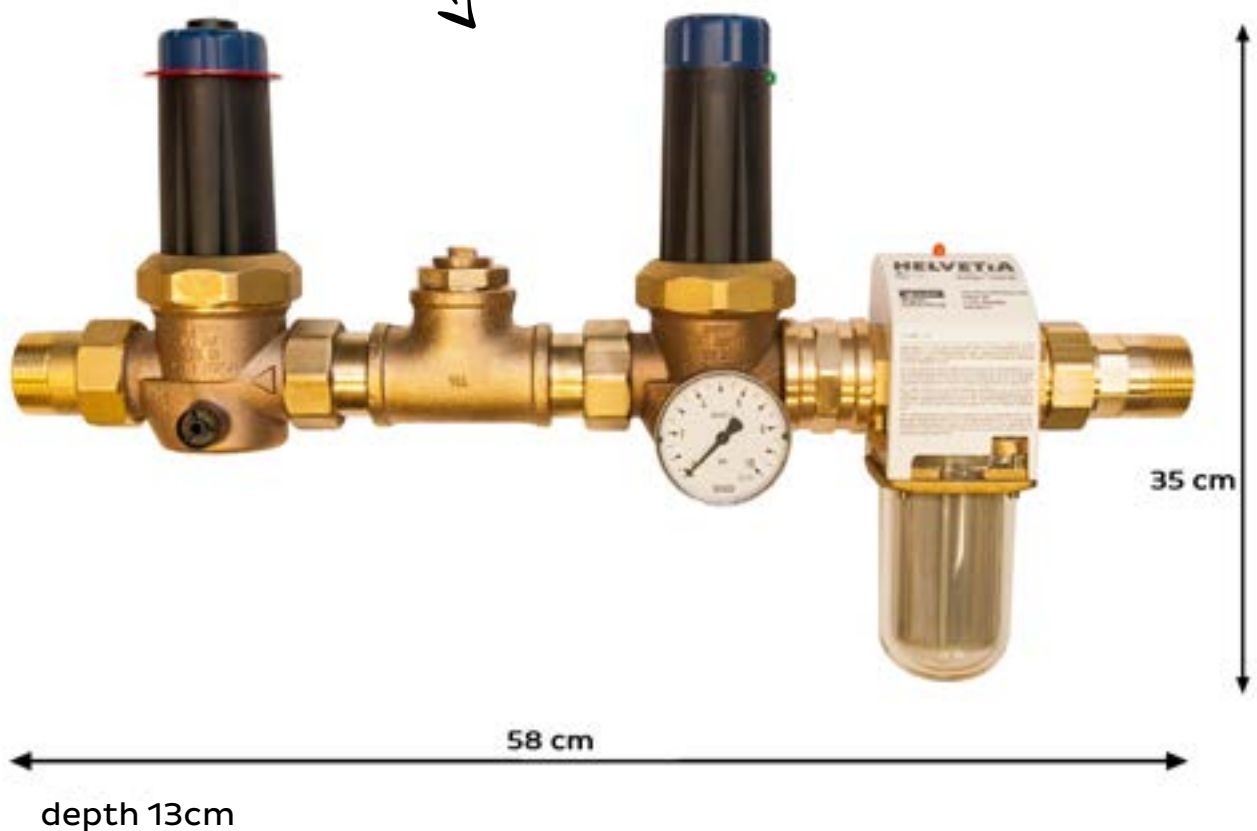

**Inhalt/Content****K&K Valve combination #033190000-A**

Please note the following details:	3
1. Function:	4
2. Components of the valve combination:	5
3. Mounting:	6
3.1 Installation position of the valve combination:	6
3.2 Appropriate locations	6
3.3 Mounting of valve combination:	7
3.4 Explanations:	7
4. Test run / Initiation:	9
4.1 Check or adjust internal pressure:	9
4.2 Check water flow to the pump:	9
4.3 Testing pump operation:	10
4.4 Setting vacuum valve UDV / water supply regulation	10
4.5 Fine adjustment of flow rate / stroke volume in pump head	11
5. Explanations of the K&K valve combination	13
5.1 Tasks of the K&K valve combination	13
5.2 Aufgaben der einzelnen Komponenten der K&K Ventilkombination	14
6. Proper function	15
7. Prevention of frost damage	16
7.1 Avoidance of frost damage to the <i>K&amp;K water pump</i>	16
7.2 Avoidance of frost damage to the <i>K&amp;K valve combination</i>	16
7.3 Winter season handling / drainage of the K&K valve combination	17
7.4 Restart of the K&K waterpump and the K&K valve combination after the frost period	19
8. Defect analysis	20
9. Replacement of leather sleeve at piston of K&K water pump	23
10. OPTIONALLY: Expansion vessel K&K #3990096 in the event of pressure surges in the pipeline network	25
11. Spare parts list	26
12. Maintenance advice	28
12.1 Routine inspections:	28
12.2 Annual main inspection	28

**Please note the following details:**

- Only suitable for K&K water pump 0-33130-000 and 0-33130-001.
- Installation and connection only by a plumbing installer company!
- Preparation of the drinking water connection in accordance with DIN 1988 „Technical rules for drinking water installations“, in particular with regard to the use of an appropriate backflow prevention.
- All special tools supplied with the device as well as all device-specific documents which are or could be important for safety management in accordance with DIN EN 1176-7, such as invoice, delivery note or order confirmation, original assembly instructions and maintenance instructions must be forwarded to the responsible authorities.

**Winter storage:****Danger of frost damage!****Valve combination in the winter months:**

- disassemble and store frost-free !  
OR
- Ensure frost-free operation by carefully draining the valve combination!
- See notes in section 7 „Avoiding frost damage“.
- Safe operation is only possible down to +5°C.
- Frost or freezing water inside the valve combination will destroy the valve combination.
- No warranty for damage caused by frost.

## 1. Function:

The valve combination prevents the unhindered continuous flow of pressurized water through the pump. The pressurized water is shut off by the valve combination. Without the valve combination, water would flow continuously:

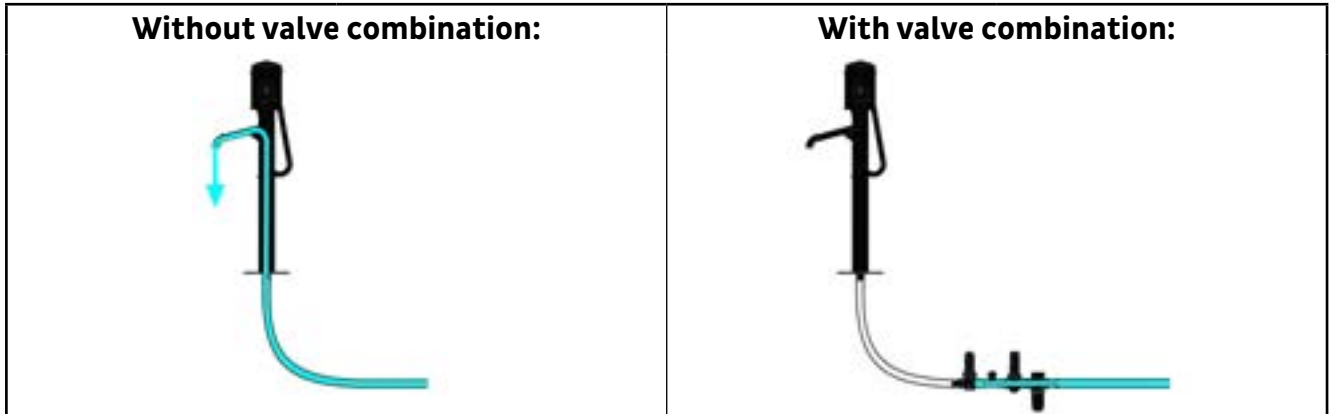

If a vacuum is generated at the outlet side of the valve combination, the valve combination opens the flow and releases it until atmospheric pressure is restored at the outlet side:

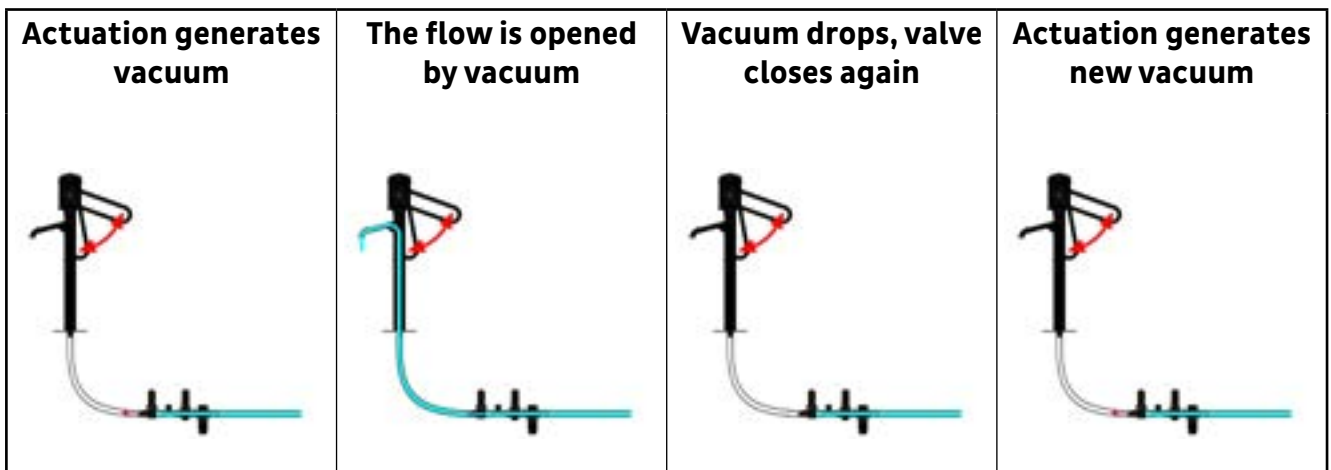

If K&K water pump and K&K valve combination are connected correctly in accordance with the K&K installation instructions and if the specified maximum distances are observed, and if the pump drive (hand swivel or handwheel) is actuated then following happens:

- a vacuum between the pump piston and the valve combination is created
- This vacuum causes the vacuum valve to open as soon as the valve closing force is exceeded. Now water is let through to the pump.
- As soon as the negative pressure has decreased, the valve closes again so that the water flow is interrupted.

When operating a K&K water pump on a pressurized water line, the valve combination prevents the water flow when not actuated, but releases the amount of water corresponding to the stroke volume when the drive is actuated.

**2. Components of the valve combination:**

The K&K valve combination substantially consists of three commercial components:

- a fine filter to protect the subsequent valves from dirt within the pipes
- a controllable pressure reducing valve 1¼" incl. a manometer for prevailing pressure display
- a controllable pressure reducing valve 1¼" modified by K&K to serve as vacuum valve

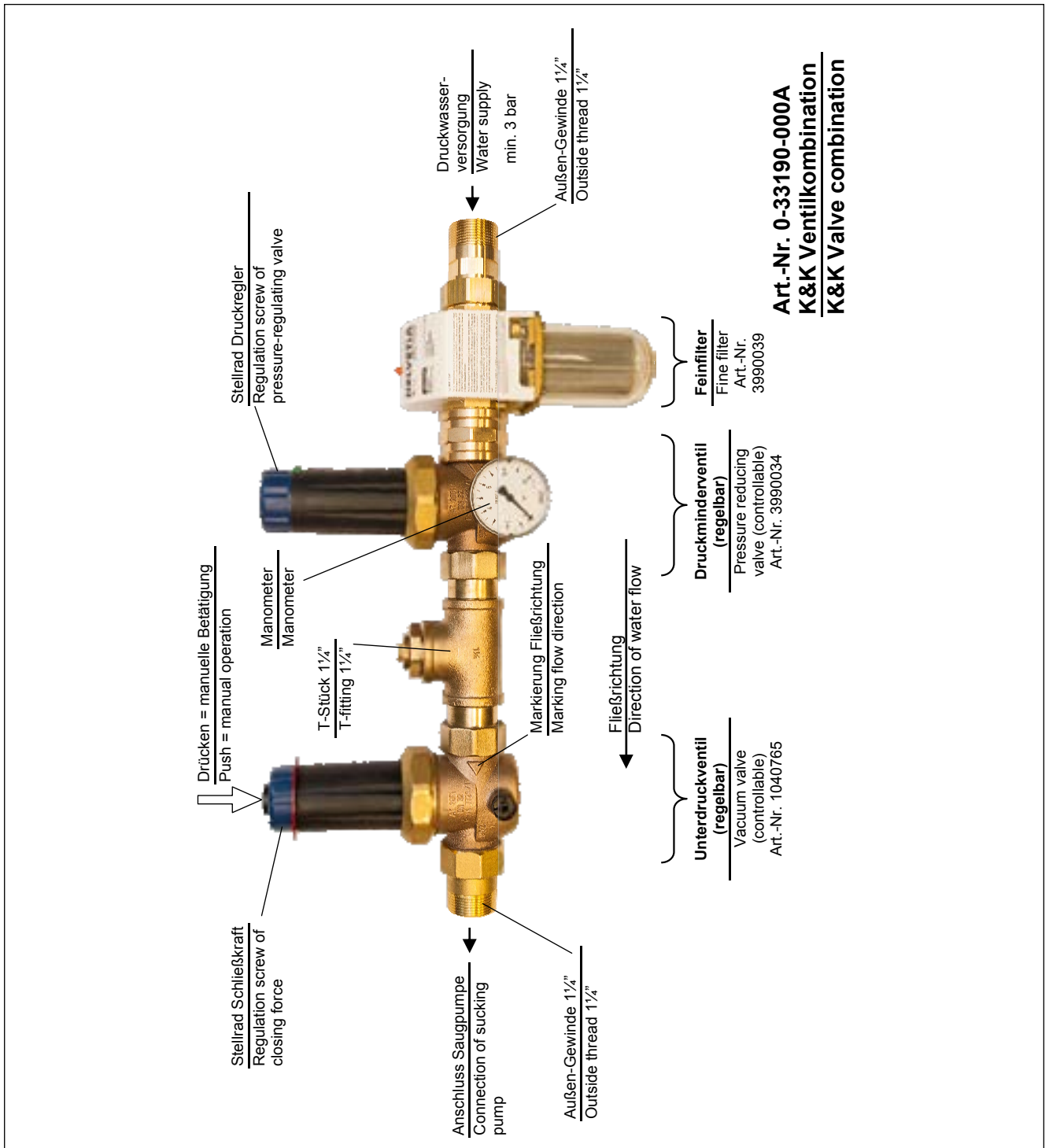

**Art.-Nr. 0-33190-000A**  
**K&K Ventilkomination**  
**K&K Valve combination**

### 3. Mounting:

#### Location of the water pump:

- Consider the space requirements
- Consider the specifications in superordinate installation instructions such as water play structures or combinations!

#### Appropriate fastening methods for the K&K Water pump:

- Dowelling**
- Installation on K&K Flange tube**
- Installation on K&K ring-shaped foundation**
- Installation on K&K platform (or other platforms)** The pump is always fixed through 4 holes in the foot flange. See separate water pump instructions for more details on the above mounting options a. to d..

#### 3.1 Installation position of the valve combination:

- **Ventilkombination** Install valve combination horizontally
- **Observe flow direction**, see arrow markings on the valves! The valve combination must always be positioned at a level below the pump outlet!

#### 3.2 Appropriate locations

##### a. shaft:

- near the pump (max. horizontal distance 50 m)
- Minimum inner diameter  $\varnothing$  1,00 m
- Shaft depth: for **frost-proof installation** of the valve combination
- with drained sole
- level below pump outlet!



##### b. terminal compartment / building

- near the pump (max. horizontal distance 50 m)
- for **frost-proof installation** of the valve combination
- level below pump outlet!



##### c. platform

- pump platform made by K&K with integrated valve combination
- **If there is a risk of frost, remove the valve combination or drain it carefully**
- level below pump outlet



### 3.3 Mounting of valve combination:

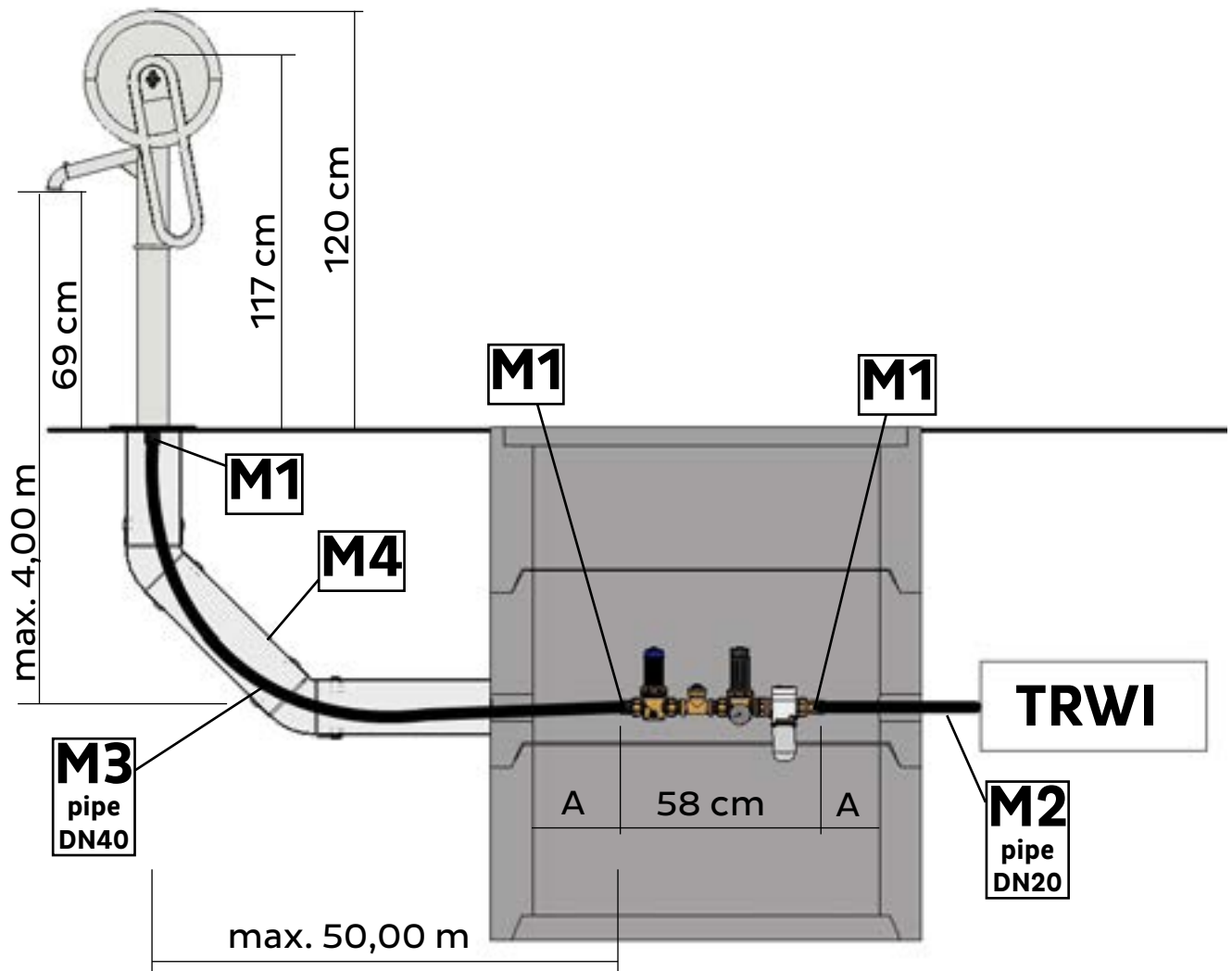

### 3.4 Explanations:

- Installation and connection of the valve combination must be carried out by an installation company.
- Before installation, the water pipes must be carefully flushed to remove any dirt.
- All pipes and connections must be suitable for drinking water and air- and watertight.
- The pump must have its **own separate connection** to the main line; no other consumers should be connected to this connection, as otherwise there may be interactions between the pump and the consumers, e.g. pressure surges; the line is also depressurised briefly during the pumping process, so that problems for other consumers may also result from this!

- **TRWI:**
    - When connecting the K&K valve combination to the public network of a water supply company, the **DIN 1988 Technical Rules for Drinking Water Installations (TRWI)** must be observed, in particular by using the prescribed **backflow prevention**.
    - Resting pressure of the connected water pipe: **3 - 6 bar**
  - **M1:**
    - K&K water pump connection pipe: **External thread 1 1/4 inch.**
    - K&K valve combination connection piece: on both sides **external thread 1 1/4 inch.**
  - **M2:**
    - On-site pipe material: Vacuum-resistant pipe (e.g. PE pipe)
    - Water supply: **Minimum** pipe cross-section **3/4 inches DN 20**
    - A larger cross-section enables a larger flow rate of the connected K&K water pump.
  - **M3:**
    - On-site pipe material: Vacuum-resistant pipe (e.g. PE pipe)
    - Water supply **from** valve combination **to** pump: **Minimum** pipe cross-section **1 1/2 inches DN 40** the water pipe has to be **FLEXIBLE** below the pump, to make the air- and watertight connection possible.
  - **M4:**
    - Recommendation for a flexible conduit: Installation in empty conduit from valve combination to pump:
    - Material Empty conduit provided by customer: e. g. plastic waste water pipe DN 150, 2x bend 45° with straight pipe of length 0,50 m between the bends
  - **A:**
    - min. 15 cm straight run before und after the valve combination
- 
- The **vertical distance** between valve combination and pump outlet **must not exceed 4 m.**
  - The **horizontal distance** between valve combination and pump outlet **must not exceed 50 m.**
  - Location of the water pump: see section „3.2 Aproprate locations“ auf Seite 9
  - Possibility of ensuring frost resistance or drainage of the valve combination and pipes, see section „7. Prevention of frost damage“ auf Seite 16

**Note:** If the water supply to the pump is interrupted (by a timer or similar), the pump handle must be secured against operation (e.g. by the K&K locking device Art. No. 1040639 (so-called "pump lock")). This prevents the pump handle set back due to an increasing negative pressure.



## 4. Test run / Initiation:

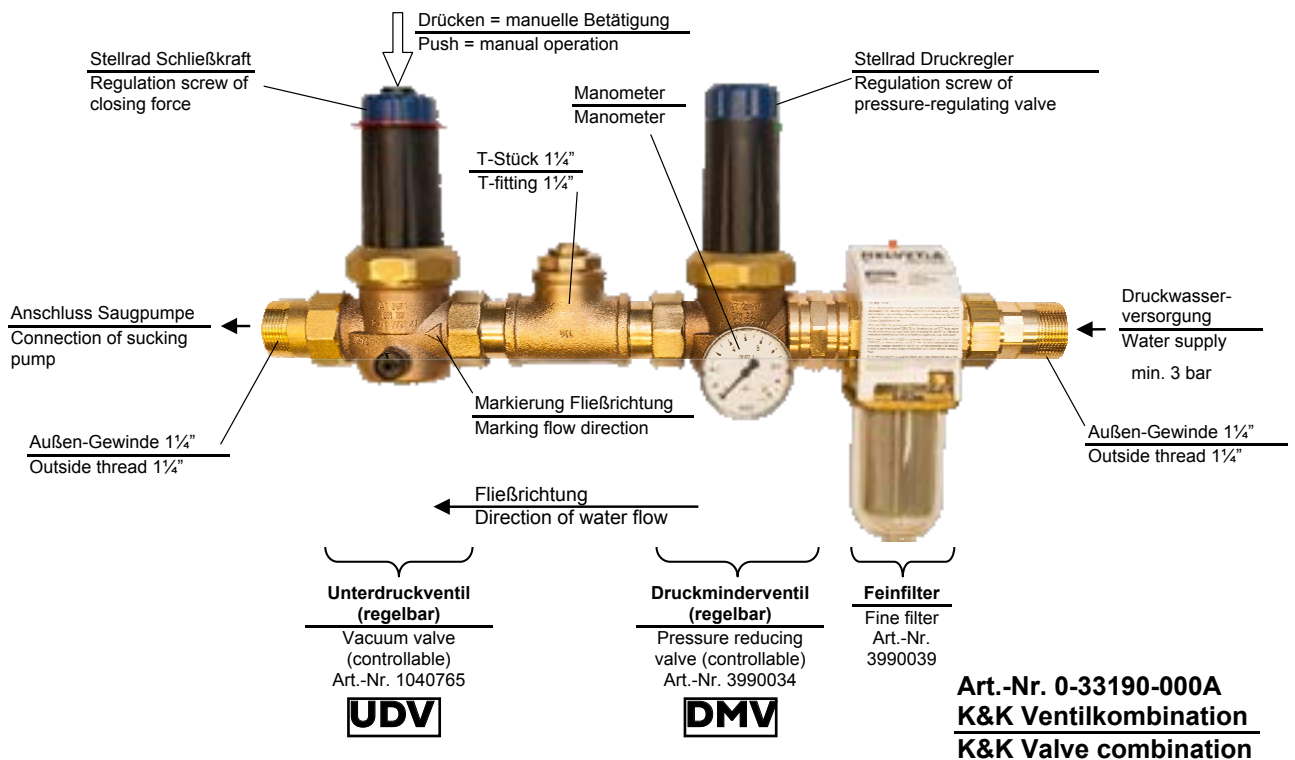

### Factory setting:

The vacuum valve (**UDV**, on the left in the picture) is set at the factory to an internal water pressure of 3 bar. Please make sure that the required line cross-sections (see sections „3.3 Mounting“ see page 7 and „3.4“ see page 7) are maintained!

### 4.1 Check or adjust internal pressure:

- Check the manometer: Internal pressure should be 3 bar.
- If the water pressure is at least 3 bar, set an internal pressure of 3 bar at the pressure reducing valve (**DMV**, on the right in the figure).
- For setting the pressure, slacken the screw (2) in the knob (3) at **DMV**. Turn counter-clockwise (-) for decreasing, clockwise (+) for increasing the pressure

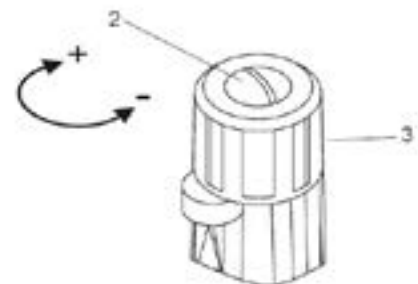

### 4.2 Check water flow to the pump:

- At (**UDV**): Press in the black plastic cap until water emerges automatically from the pump.

### 4.3 Testing pump operation:

- Operate pump: Move the pump handle or handwheel until water emerges from the pump. Per lever pull or revolution a water quantity of about 0.15 litres (corresponds to about 1 glass of water) is pumped.

### 4.4 Setting vacuum valve UDV / water supply regulation

- Case A: Water flows out of the pump at rest:**
- The closing force at the vacuum valve (**UDV**) is too small.
- The closing force at the vacuum valve (**UDV**) must be increased (+).
- When the pump is dripping, the preset spring force on the vacuum valve (UDV) must be adjusted by turning the blue knob. The direction of rotation (+/-) can be seen on the valve.

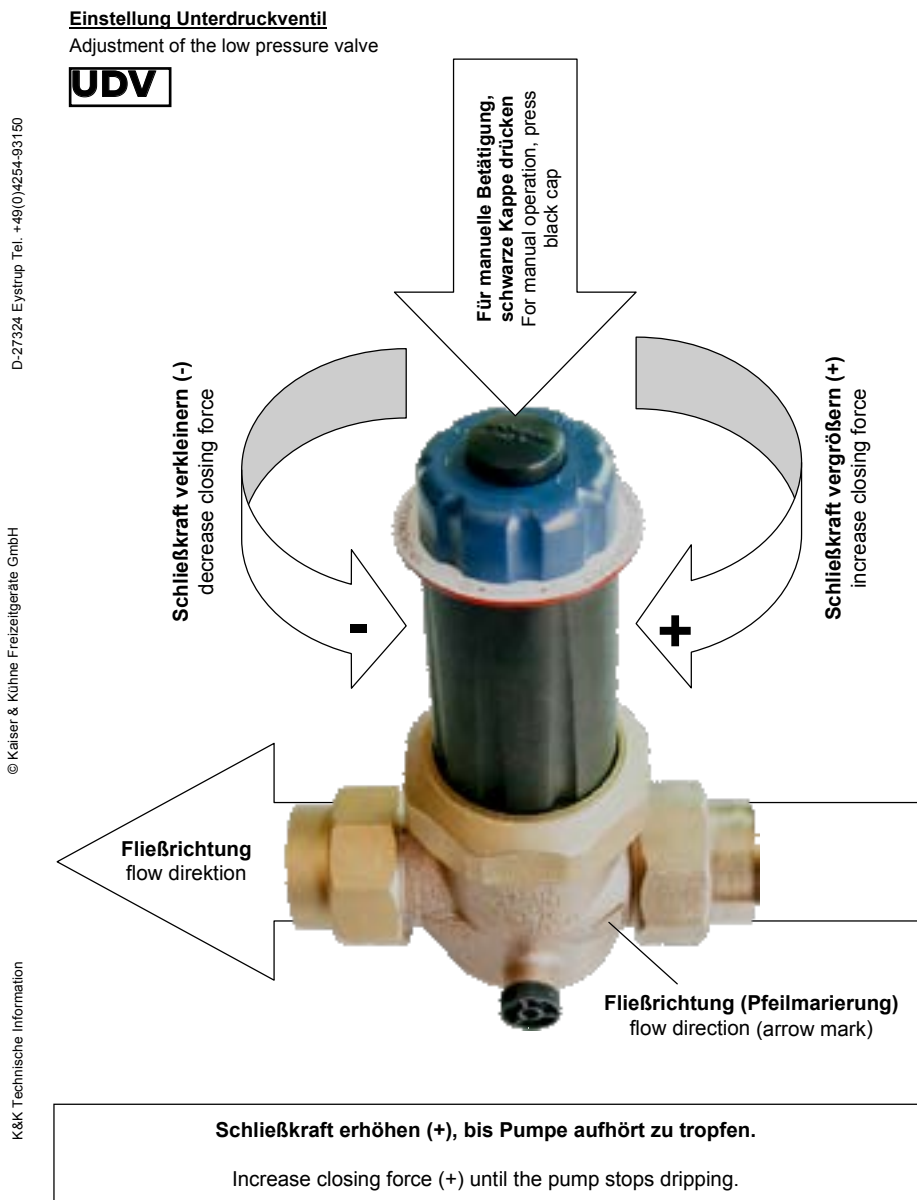



**UDV** K&K Unterdruckventil / Low pressure valve  
(Teil der K&K Ventilkombination / part of K&K valve combination 0-33190A-000)

- **Case B: When actuated, the pump swivel or handwheel strikes back.**
- The closing force at the vacuum valve (**UDV**) is too high
- The closing force at the vacuum valve (**UDV**) must be reduced (-).
- The preset spring force on the vacuum valve (**UDV**) must be adjusted by turning the blue knob. The direction of rotation (+/-) can be seen on the valve.

#### **4.5 Fine adjustment of flow rate / stroke volume in pump head**

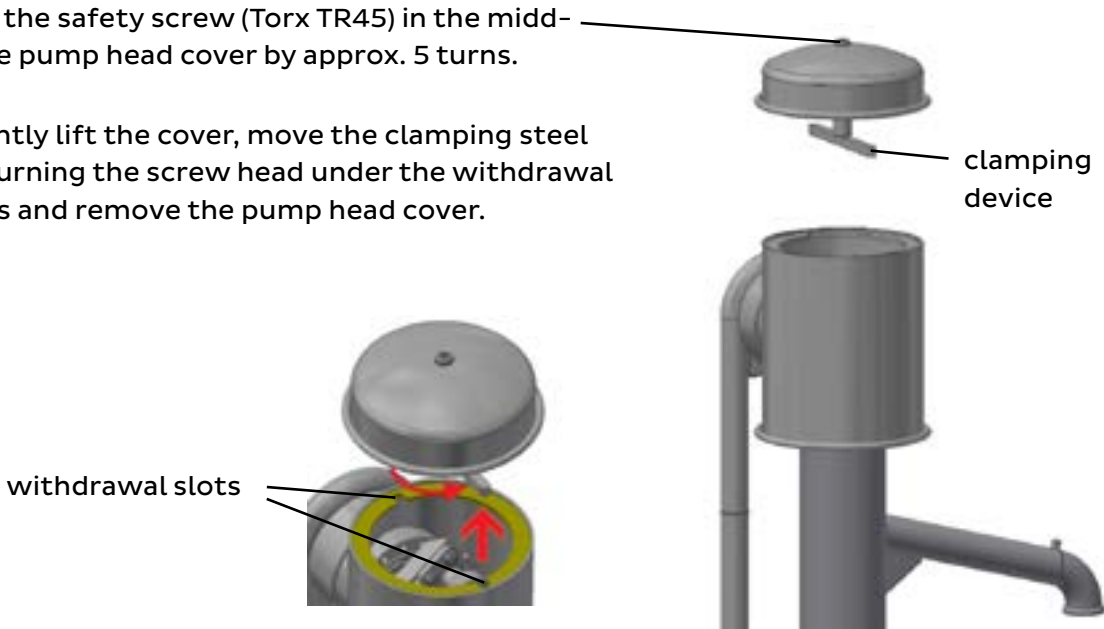
- The preset flow rate can be changed to a certain extent.
- The change also changes the pump resistance:
  - » High flow rate (approx. 0.2 litres) = large stroke = large pumping resistance
  - » Small flow rate (approx. 0.05 litres) = small stroke = small pumping resistance
- Factory setting: average flow rate (approx. 0.15 litres)

<b>Fine adjustment of flow rate in pump head</b>	
<p>Loosen the safety screw (Torx TR45) in the middle of the pump head cover by approx. 5 turns.</p> <p>Slightly lift the cover, move the clamping steel by turning the screw head under the withdrawal slots and remove the pump head cover.</p>	
<p>Factory setting of the eccentric slide: middle position</p>	

Release the 4 clamping nuts (M8 - wrench size 13 mm) on the eccentric slide 1-2 turns. **Do not unscrew completely!**

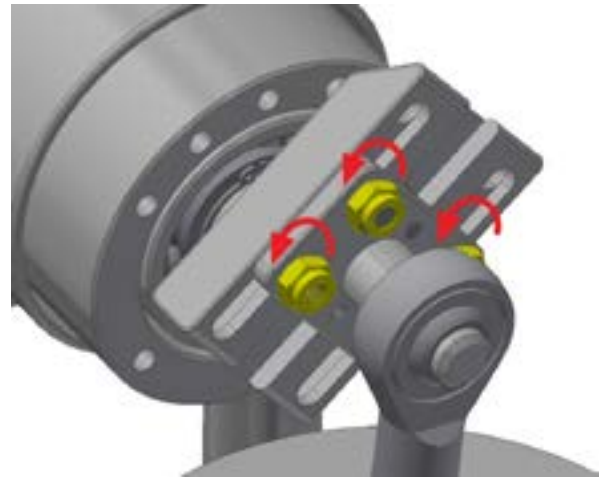

Move the eccentric slide to the required position.

Large stroke = large flow rate = large pumping resistance

Large stroke

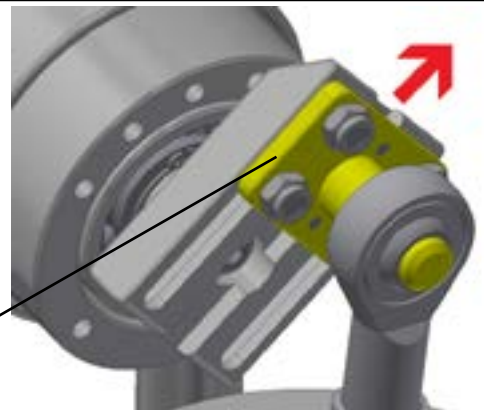

Small stroke = small flow rate = small pumping resistance

small stroke

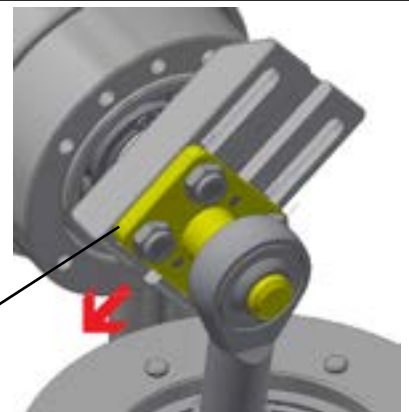

Fasten the 4 clamping nuts



Place the pump head cover and clamping steel on the pump head and screw tight again with the safety screw.



## 5. Explanations of the K&K valve combination

### 5.1 Tasks of the K&K valve combination

The K&K water pump is basically a manually operated, mechanical pump. It is designed as a suction pump, i.e. it is able to suck in water from an unpressurised water supply (well, brook, cistern, reservoir, groundwater or similar) and to hold the water column.

The term suction pump also means that during normal operation between the water level of the water supply and the pump piston there is only vacuum, i.e. pressures below atmospheric pressure within the water-carrying pipes involved. **Operation as a suction pump is not the subject of these instructions (see separate instructions).**

If the **pump** is to be connected **to a pressurized water pipe**, the problem arises that if the K&K water pump is operated directly on a pressurized water pipe, the water would flow through the pump unhindered (i.e. uninterrupted and not controllable) and the actual pumping process would no longer have any function. The pump would then be comparable to an open tap: water would flow continuously.

When operating a K&K water pump on a pressurized water pipe, the K&K valve combination is therefore absolutely necessary as a necessary technical link. It prevents the water flow if the Schwengel does not move, but releases the amount of water corresponding to the stroke volume when it is actuated.

## 5.2 Aufgaben der einzelnen Komponenten der K&K Ventilkombination

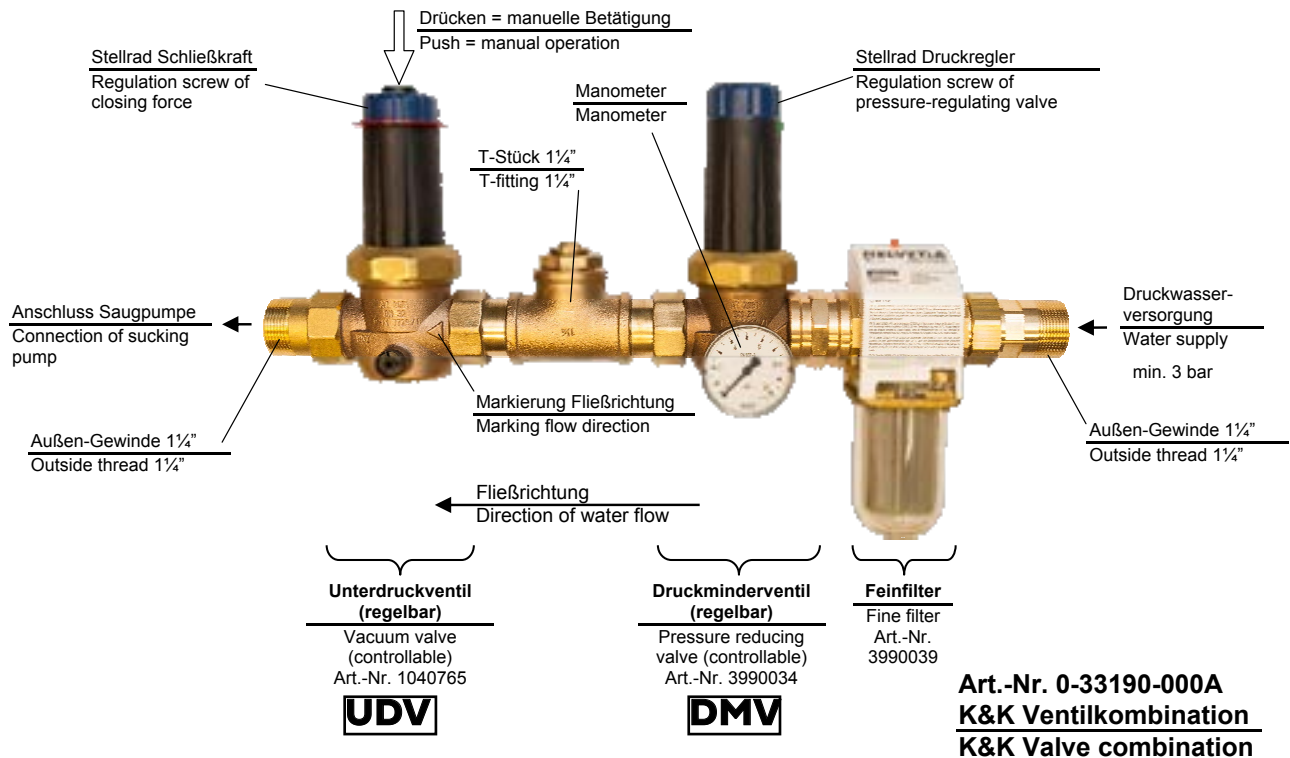

After the fine filter, a pressure reducing valve (**DMV**) is first arranged in the direction of flow, which serves to reduce the undefined water pressure (at least 3.0 bar) in the supply line to a constant pressure of 3.0 bar required for the correct functioning of the system.

The manometer on the same component serves as an aid for setting the operating pressure. It indicates the water pressure between the pressure reducing valve (**DMV**) and the downstream vacuum valve (**UDV**)- not the pressure upstream of the pressure reducing valve (**DMV**) in the supply line!

The next component in the direction of flow is a vacuum valve (**UDV**). It takes over the actual task of the valve combination.

In its original state it is the same pressure reducing valve as described above. Due to the changes made by K&K, it now acts as a vacuum valve. The machining traces visible on the valve (modified plastic parts) thus originate from the reworking of the valve at K&K; it is therefore a component that has been deliberately modified to achieve a different function.

The preset spring force may have to be adjusted by turning the blue knob when the pump is dripping. The direction of rotation (+/-) can be seen on the valve.

In summary, the function of this combination can be described as follows: If the K&K water pump is connected behind the vacuum valve (**UDV**), a vacuum is generated in the space between the pump piston and the vacuum valve when it is actuated and when the water pump and valve combination are correctly connected in accordance with the K&K installation instructions and the maximum distances specified in the installation instructions. This causes the vacuum valve to open as soon as the generated vacuum has exceeded the closing force; as soon as the vacuum drops, the valve closes again so that the water flow is interrupted again.

## 6. Proper function

A proper function is only guaranteed in case fundamental principles in the range of water installation are focused on during installation, operation and maintenance

- Tightness of the connecting components
- Ensure cleanliness of the water (fine filter!)
- Compliance with water supply pressure (3,0 bar at least)
- Compliance with maximum level difference and horizontal distance between valve combination and water pump
- Sufficient cross sections. Above all, the supply pipe for the valve combination must continuously provide a nominal diameter of DN 40, any cross section reduction may affect the function of the pump!
- Proper installation of the valve combination in water flow direction
- Precise water pressure adjustment at the pressure reducing valve (ahead of the vacuum valve)
- Adjustment of the closing force of the vacuum valve in the event that the pump "drips"
- Frost precaution to avoid frost damage has been carried out

## 7. Prevention of frost damage

### Winter storage:

#### Danger of frost damage!

#### Valve combination in the winter months:

- **disassemble and store frost-free !**  
**OR**
- **carefully drain the valve combination!**
  
- **Safe operation is only possible down to +5°C.**
- **Freezing water inside the valve combination will destroy the valve combination.**



### **7.1 Avoidance of frost damage to the K&K water pump**

Due to the danger of destruction by frost, the pump head of the K&K water pump must be dismantled and stored during the winter season or before temperatures below 4° C occur.

Otherwise, or by means of chaining the handle, the company Kaiser&Kühne Freizeitgeräte GmbH will not accept any responsibility for a damage caused hereby.

### **7.2 Avoidance of frost damage to the K&K valve combination**

Due to the danger of destruction by frost, preparations must be taken to avoid frost damage during the winter months or before temperatures below 4° C occur.

If the K&K valve combination is installed in an area that is not frost-proof, the valve combination must also be dismantled, drained and stored.

Otherwise the drainage of the valve combination and the line is sufficient.



**7.3 Winter season handling / drainage of the K&K valve combination**

- Keep at hand supplied winter cover accessory.



- Shut off water supply up to valve combination.

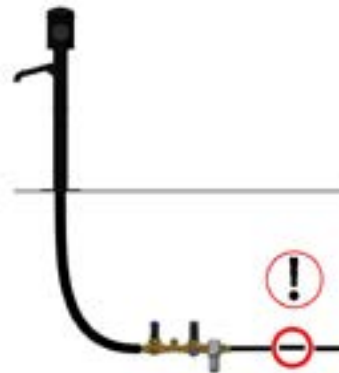

- Remove black plastic plugs from the K&K valve combination (= a total of 3) or, where appropriate, uninstall K&K valve combination entirely.



- Unscrew pump head and take it off.
- The inner holding valve is visible in pump column after taking off the head.
- Lift off inner holding valve from its seat. Optionally use a steel wire as appropriate appliance.

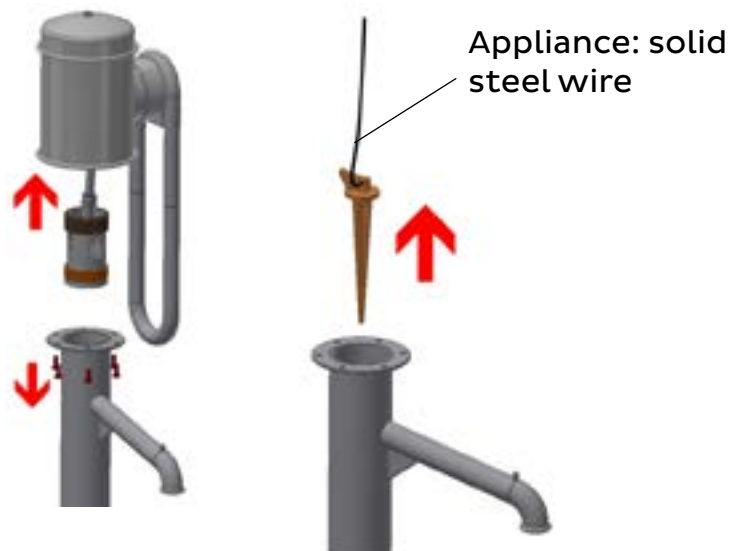

- The remaining water between pump and valve combination pours out of the outlets opened before.

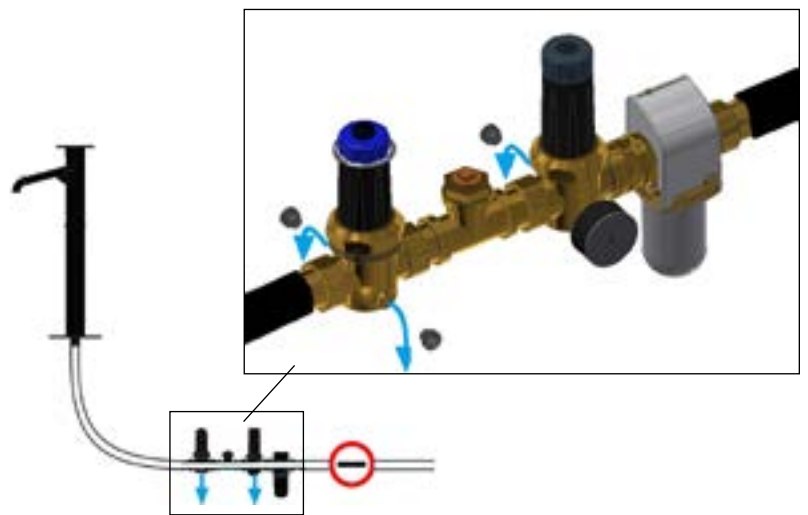

- As soon as the pipe is completely empty: Insert the black plastic plugs again.
- Reinsert the inner holding valve into its seat.



- Fasten the supplied winter cover plate on top of the pump column.
- Store the pump head and where appropriate, store the valve combination.



**7.4 Restart of the K&K waterpump and the K&K valve combination after the frost period**

- If the leather cup at the bottom of the piston has hardened during storage soak it in water for 24 hours before reinstallation.



- Unscrew and remove winter plate from water pump column.





- Where appropriate, reinstall the K&K valve combination.



- Set pump head onto water pump column and fix screws.
- Restart pump operation as described in chapter „4. Test run / Initiation:“ see page 9



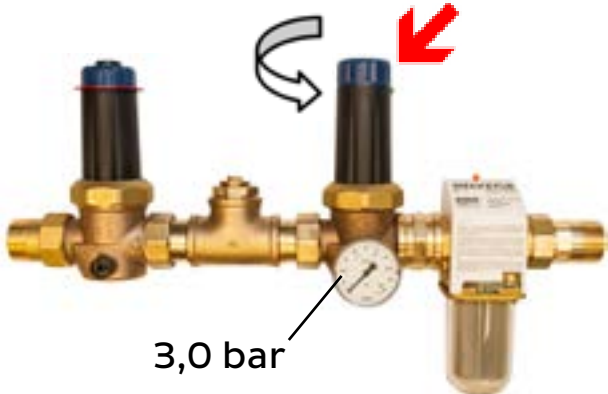

**8. Defect analysis**

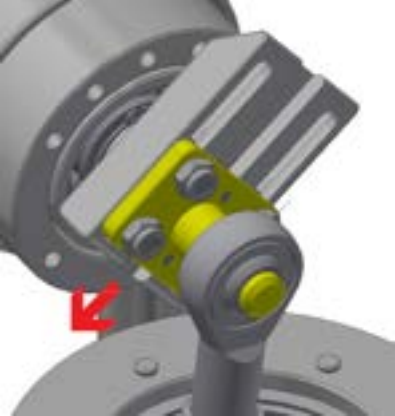
Defect	Cause	Remedy
<p style="writing-mode: vertical-rl; transform: rotate(180deg);"><b>The Pump is dripping resp. current water flow out of pump</b></p>	<ul style="list-style-type: none"> <li>Adjustment of closing force of vacuum valve is too low</li> </ul> 	<p>Increase closing force of vacuum valve by turning in direction "+"</p>
	<ul style="list-style-type: none"> <li>Valve combination is polluted</li> </ul> 	<p>Clean fine filter; if necessary, dismantle valve combination and clean it</p>
	<ul style="list-style-type: none"> <li>Pressure at valve combination is too high</li> </ul> 	<p>Reduce pressure, 3 bar required</p>

**8. Defect analysis**

Defect	Cause	Remedy
Pump handle strikes back	<ul style="list-style-type: none"> <li>Pump stroke too large/volume flow too high</li> </ul> 	<p>Adjust pump stroke/ reduce volume flow (see chapter „4.5 Fine adjustment of flow rate / stroke volume in pump head“ see page 11)</p>
	<ul style="list-style-type: none"> <li>Adjustment of closing force of vacuum valve is too low</li> </ul> 	<p>Decrease closing force of vacuum valve by turning in direction "-"</p>
	<ul style="list-style-type: none"> <li>Air in pipes</li> </ul>	<p>Evacuate the air from the pipes</p>
	<ul style="list-style-type: none"> <li>Installation dimensions (maximum distances) neglected</li> </ul>	<p>Revise distances according to enclosed technical drawing at chapter „3.3 Mounting“ see page 7</p>
	<ul style="list-style-type: none"> <li>Pipes blocked, distorted or squeezed (e.g. by a vehicle pass over)</li> </ul>	<p>Check pipes for free flow</p>
	<ul style="list-style-type: none"> <li>Installation with a clock timer: pump operation in switch-off time</li> </ul>	<p>Adapt circuit times</p>

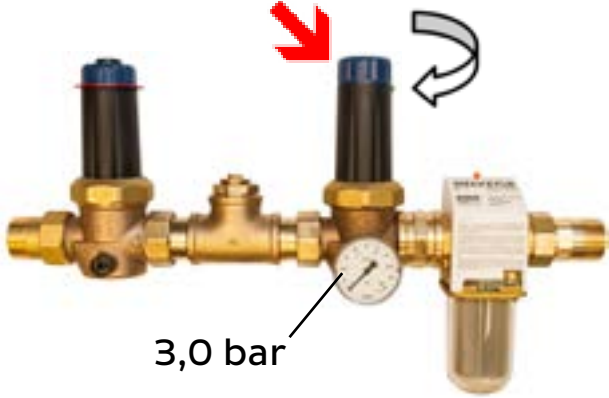
**8. Defect analysis**

Defect	Cause	Remedy
<p style="writing-mode: vertical-rl; transform: rotate(180deg);"><b>The pump does not take water and can be operated with unusually low effort</b></p>	<ul style="list-style-type: none"> <li>No water in the system</li> </ul>	<p>Connect pressurized water</p>
	<ul style="list-style-type: none"> <li>Pump draws air due to leakage in pipe system.</li> </ul>	<p>Check pipe system for leaks</p>
	<ul style="list-style-type: none"> <li>Water pressure is too low</li> </ul>  <p>3,0 bar</p>	<p>Increase pressure, 3 bar required</p>
	<ul style="list-style-type: none"> <li>Hardened or worn leather cup at pump piston</li> </ul> 	<p>Soak leather cup for 24 hours or replace it.</p>
<p><b>Pressure surges in the pipeline network</b></p>	<ul style="list-style-type: none"> <li>no separate connection</li> </ul>	<p>Create separate connection or water hammer damping by means of expansion vessel (no. 3990096).</p>

## 9. Replacement of leather sleeve at piston of K&K water pump

1. Remove the pump head including rods and pistons from the pump column.



2. For easy handling please first remove piston from main rod. Thereto take off one of the retaining rings which fix the pump axle inside piston, using a suitable gripper. Then the axle can be removed and the piston is loose.





3. Now clamp the piston in vertical position (as in use inside pump) into a vice. The clamping jaws should only fix the small area below leather collar. Tighten vice very hard!



4. Insert a suitable tube or spindle as a lever into oval openings of top part of piston. By turning the top part of piston with lever counter-clockwise (right-handed thread) the piston top will be removed from bottom part.

Please note: the thread is provided with adhesive to prevent it against unintentional remove; this may make remove more difficult!

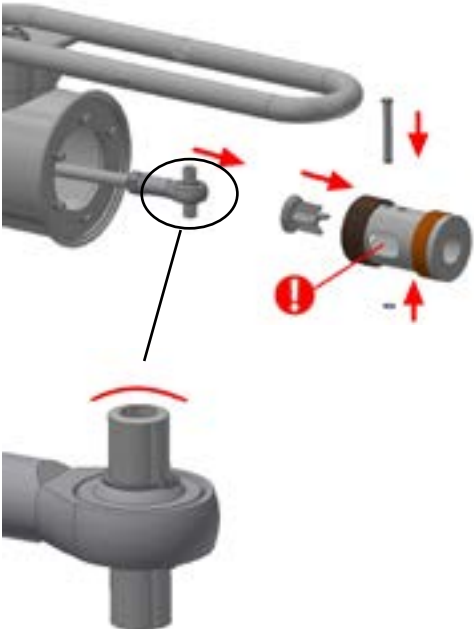

<p>5. After having removed the worn leather sleeve please clean inside and outside threads of piston parts.</p>	
<p>6. Before assembling the piston parts with new leather cup the threads need to be lubricated with adhesive as screw locking (like Loctite or similar) to make sure that parts do not come loose unintentionally.</p> <p>(The leather sleeve differs in volume and shape due to different humidity conditions and therefore does not grant a durable and safe)</p>	
<p>7. When assembling piston and main rod and axle please take note of mounting direction of distance bush inside piston (radius facing towards shell) and alignment of outlet hole.</p> <p>Do not forget inserting valve inside piston before mounting of the rod to piston!</p>	



**10. OPTIONALLY:****Expansion vessel K&K #3990096  
in the event of pressure surges in the pipeline network**

Pressure expansion vessel for use with pressure surge problems in adjacent buildings of water playgrounds where K&K water pumps in combination with the K&K valve combination cause noise.









Recommended pre-pressure: Static pressure of water supply minus 0,2 bar.  
(Factory setting pressure 4,0 bar.)



Any installation position is possible. Connection preferably at the prepared 3/4" connection between pressure reducer and vacuum valve of the K&K valve combination. If the accommodation is not possible due to lack of space, other installation locations are also possible but less effective.

Maintenance: At least annually. Pressure can be built up using a compressor in combination with a tyre inflator (it is best to note the ideal pressure with a waterproof pen on the vessel).

Please follow the instructions supplied with the expansion vessel.



11.Spare parts list		
Item no.	Description	Image
3990039	Filter for K&K Valve combination/Water dispenser	
3990055	Coupling	
3990034	Pressure-reducing valve	
3990028	Manometer	
3990093	T-piece	
3990094	Reducer	
3990095	Plug with rim, square drive	
1040765	Low pressure valve 1 1/4"	

11.Spare parts list		
Item no.	Description	Image
1040551	Leather cup for pump piston	
3990096	Expansion vessel (optional accessory)	

## 12. Maintenance advice

### 12.1 Routine inspections:

<b>1x per week</b> (or different, determined by local factors)	<ul style="list-style-type: none"> <li>• Check components for tightness and cleanliness</li> </ul>
	<ul style="list-style-type: none"> <li>• Check components for vandalism, e.g. missing or damaged components</li> </ul>
	<ul style="list-style-type: none"> <li>• Check components for consequences of weather influences, e.g. rain, storm or frost.</li> </ul>
<b>1x per month</b> (or different, determined by local factors)	<b>in addition to all the above maintenance work:</b>
	<ul style="list-style-type: none"> <li>• Check components for wear, replace if necessary.</li> </ul>
	<ul style="list-style-type: none"> <li>• Check connections and screw connections for tight fit, tighten if necessary.</li> </ul>
	<ul style="list-style-type: none"> <li>• Replace defective components if necessary.</li> </ul>
	<ul style="list-style-type: none"> <li>• Check the sieve in the fine filter for impurities. If contaminated, clean or replace the sieve.</li> </ul>
<h3>12.2 Annual main inspection</h3>	
<b>1x per year</b> (or different, determined by local factors)	<b>in addition to all the above maintenance work:</b>
	<b>At the beginning of the frost period:</b> <ul style="list-style-type: none"> <li>• Safe operation is only possible down to +5°C</li> <li>• <b>Dismount</b> the pump head incl. rod and piston and <b>store it frost-free.</b></li> <li>• Dismount the valve combination in the winter months and store it frost-free OR ensure frost-free conditions.</li> <li>• Alternatively drain the valve combination carefully.</li> <li>• Before restart: Clean sieve in the fine filter or replace it.</li> </ul>