

1. Assign location of equipment considering the space (falling space) requirement.
2. Excavate soil for foundations, according to drawing.
Please note: To achieve a maximum of stability and a safe installation a normal level of soil solubility is required.
3. Build in layer of gravel, approx. 10 cm thick, as distance between fore-part of steel post and plain base of foundation.
4. Put posts according to post number (072/082) into their respective holes of foundations. Play level mark (= pin), conforms to the mounting depth of post. Align posts with the help of play level mark, according to detail drawing respectively installation plan. For installation all play level marks have to face in the same direction.
- 5. Attention: For installation of the pre-assembled components and/or single parts the screws have to be lubricated thinly with installation paste! Tighten all screws after having aligned all components.**
6. Grout in foundations with compressed concrete C20/25, chamfer the edges and cover with a surface, which shall meet the requirements for impact attenuation so that the critical height of the surfacing shall be equal to or greater than the free height of fall of the equipment (acc. to EN 1176-1).
7. Release for play after concrete foundations have set.
8. Check all screw connections according to maintenance instructions after 4-5 weeks and screw down again if necessary.
9. Please take care that all special tools (e.g. special Allen key for secured Allen screws etc.) and all specific documents which are or may be useful for safety management acc. to EN 1176-7 (e.g. invoice, delivery note, order acknowledgement, installation instructions, maintenance instructions) are forwarded to the responsible persons.

*max. free height of fall

16 x safety screw M12x25-A2

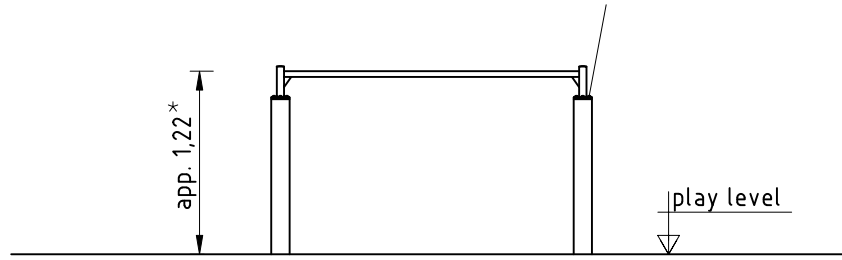

Impact area app. 19 m²

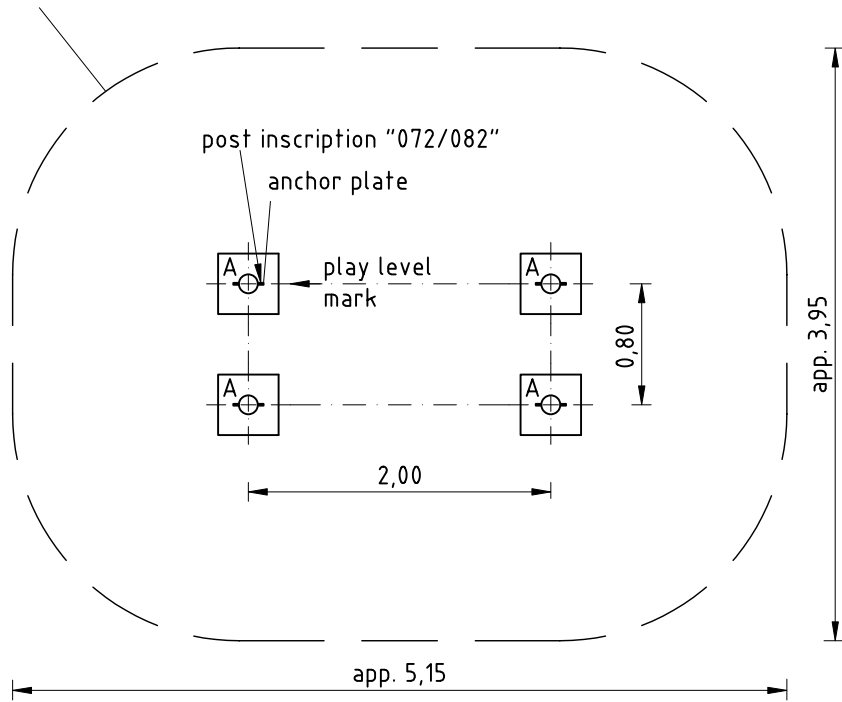

type A
scale 1:20

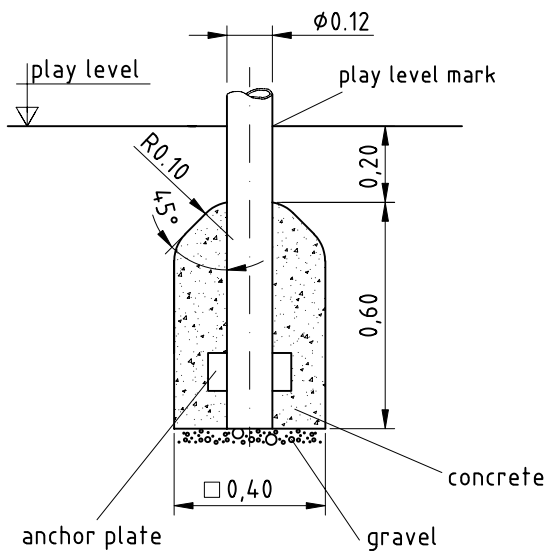

Detail play level mark
scale 1:5

